

Технические характеристики генератора

Производитель: Mercury Electronic Ind Co., Ltd.

Поставщик: ООО «НПП «Техно-ПАРК»

Научно-производственное предприятие ООО «НПП «Техно-ПАРК» разрабатывает и поставляет полосно-пропускающие радиочастотные фильтры на поверхностных акустических волнах (ПАВ) и устройства на их основе.

Temperature Compensated Crystal Oscillators [TCXO " M " and VCTCXO " VM "]



TCXO
MJF538

VCTCXO
VMJF538

SMD

1.8 V	2.5 V	3.3 V
--------------	--------------	--------------

Min.
15
MHz

Max.
2,100
MHz

Features

Mercury's QuikXO Quick-Turn TCXO that can be delivered in days, support high frequency up to 2.1 GHz. miniature product size, An integrated phase jitter performance of 300 fs RMS.

Supports all popular formats: PECL, LVDS, HCSL and CML



General specifications , at Ta = + 25°C

Model	(V) MJF538P	(V) MJF538D	(V) MJF538C	(V) MJF538Q
Output Logic	PECL	LVDS	HCSL	CML
Supply Voltage V _{DD} (code)	-- + 2.5 V ± 10% (voltage code " 25 ") + 3.3 V ± 10% (voltage code " 33 ")	+ 1.8 V ± 5% ^(*) (voltage code " 18 ") + 2.5 V ± 10% (voltage code " 25 ") + 3.3 V ± 10% (voltage code " 33 ")	+ 1.8 V ± 5% (voltage code " 18 ") + 2.5 V ± 10% (voltage code " 25 ") + 3.3 V ± 10% (voltage code " 33 ")	+ 1.8 V ± 5% (voltage code " 18 ") + 2.5 V ± 10% (voltage code " 25 ") + 3.3 V ± 10% (voltage code " 33 ")
Available Frequency Range	15 ~ 2,100 MHz	15 ~ 2,100 MHz	15 ~ 700 MHz	15 ~ 2,100 MHz
Output Load	50 Ω into V _{DD} - 2V or Thevenin equivalent	100 Ω between output and complimentary output	50 Ω to GND	50 Ω to V _{DD}
Output Logic " High " , " 1 "	V _{DD} - 1.03 V (min.) V _{DD} - 0.6 V (max.)	1.4 V (Typ.) 1.6 V (max.)	V _{DD} : 0.66V(min.) V _{DD} : 1.15V (max.)	V _{DD} - 0.085V(min.) V _{DD} = (max.)
Output Logic " Low " , " 0 "	V _{DD} - 1.85 V (min.) V _{DD} - 1.6 V (max.)	1.1 V (Typ.) 0.9 V(min.)	V _{DD} : 0.0V(min.) V _{DD} : 0.15V (max.)	V _{DD} - 0.6V(min.) V _{DD} - 0.32V (max.)
Current Consumption (V _{DD} = + 3.3 V)	100 mA (typ.) 120 mA (max.)	75 mA (typ.) 90 mA (max.)	80 mA (typ.) 100 mA (max.)	70 mA (typ.) 85 mA (max.)
Current with Output Disabie	99 mA (typ.)	74 mA (typ.)	79 mA (typ.)	69 mA (typ.)
Rise Time / Fall Time (20% to 80% Waveform)	0.4 nsec. (max.)	0.4 nsec. (max.)	0.4 nsec.(max.)	0.4 nsec. (max.)
Initial Calibration Tolerance	± 1.0 ppm. (max.) at +25°C ± 2°C.			
Frequency Stability Codes	Temperature (ref to +25°C)	± 2.5 ppm over -40°C to +85°C (default) ± 1.5 ppm over -40°C to +85°C (available)		
	Aging at Ta = +25°C	± 1.0 ppm (max.) , per year		
	Voltage Change	± 0.2 ppm (max.) , for a ± 5% input voltage change.		
	Load Change	± 0.2 ppm (max.) , for a ± 10% load condition change.		
	Reflow	± 1.0 ppm (max.) , 1 reflow and measured 24 hours afterwards.		
Duty Cycle	50 % ± 5%			
Start-up Time	5 msec (typ.) ; 10 msec. (max.)			
Storage Temperature	-55°C to + 150°C			
RMS Jitter (typ.) (12 KHz to 20 MHz)	15 MHz ~ 50 MHz : 500 fsec (typ.) , 51MHz ~ 1,200 MHz : 250 fsec (typ.)			
Control Voltage Function on Pad 1		Output Enable Function on pad 2		
Control Voltage Center and Range	+1.5V ± 1.0V for both V _{DD} = 2.5V and 3.3V		Output Enable / Disable Function	70% of V _{DD} (min.) to enable output.
	+ 0.9V ± 0.6V for both V _{DD} = 1.8V			30% of V _{DD} (max.) to disable output
Frequency Pulling Range	± 8 ppm min.		Ouput Enable Time	2.5 msec.(max.)
Linearity	± 1 % (typ.) ± 10% (max.)			Output Disable Time
Transfer Function	Positive Transfer			
Input Impedance	5 MΩ (typ.)			

Mercury www.mercury-crystal.com ■Taiwan : Tel: (+886)-2-2406-2779 / sales-tw@mercury-crystal.com

■USA : Tel: (+1)-909-466-0427 / sales-us@mercury-crystal.com ■China : Tel: (+86)-512-5763-8100 / sales-cn@mercury-crystal.com

Temperature Compensated Crystal Oscillators [TCXO " M " and VCTCXO " VM "]



TCXO	VCTCXO	SMD	1.8 V	2.5 V	3.3 V	Min. 15 MHz	Max. 2,100 MHz
MJF538_	VMJF538_						

Part Number Format and Example

Example : MJF538D33-100.000-2.5/-40+85

MJF	538	D	33	-	100.000	-	2.5	/	-40+85
Hold Type " MJF " : TCXO " VMJF " : VCTCXO	Package Size " 538 " (5.0 * 3.2 mm) 8pad	P : PECL D : LVDS C : HCSL Q : CML	Supply Voltage " 33 " for 3.3V " 25 " for 2.5V " 18 " for 1.8V	-	Center Freq. (MHz)	-	Freq. Stability (ppm)	-	Operating Temperature Range(°C)

Outline Dimensions (Unit : mm) , Suggested pad Layout for SMDs

MJF538_ , VMJF538_

Top View

Bottom View

Land Pattern

Side View

Pad Connection :

pad 1 : VCTCXO : Control Voltage TCXO : Ground pad 2 : OE pad 3 : Ground pad 4 : output	pad 5 : Complementary output pad 6 : Supply Voltage pad 7 : Do Not Connet pad 8 : Do Not Connet
---	--

Test Circuits and Output Waveforms

<p>PECL Test Circuit</p> <p>VDD = 3.3 V : R1 = R3 = 127 Ω ; R2 = R4 = 82.5 Ω VDD = 2.5 V : R1 = R3 = 250 Ω ; R2 = R4 = 62.5 Ω</p>	<p>HCSL Test Circuit</p>	
<p>CML Test Circuit</p>	<p>LVDS Test Circuit</p>	<p>LVDS Test Circuits for 1.8V only (*)</p>

Emboss Taping and Reel Specifications

[VCXO]

[(VC)TCXO]

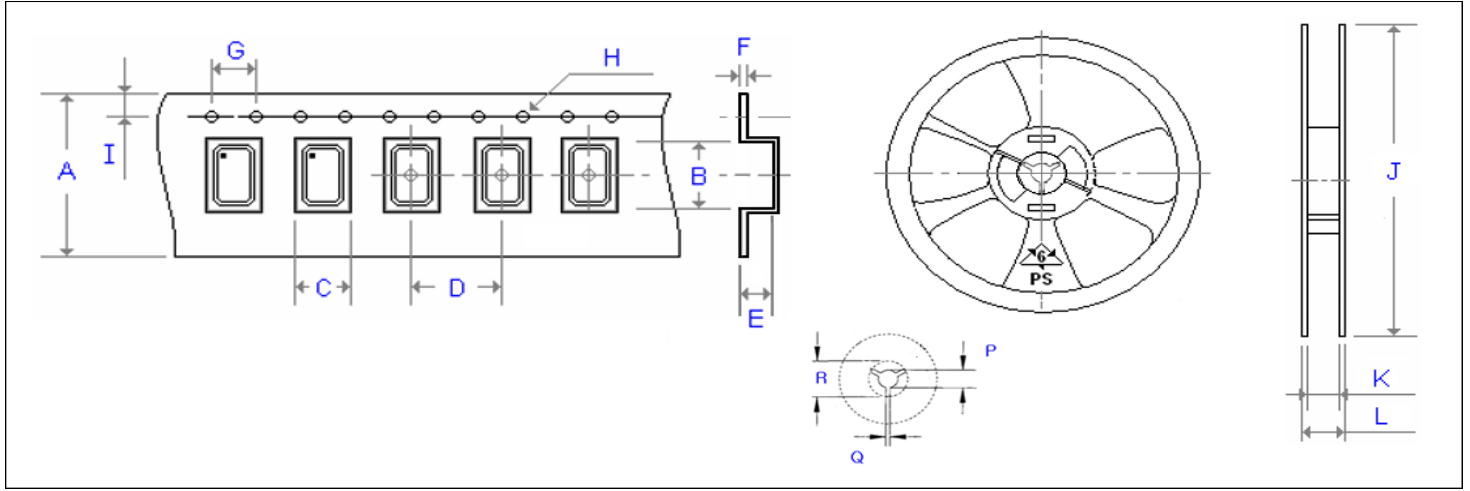

Carrier Type Dimensions (unit : mm) ±0.3mm

	A	B	C	D	E	F	G	H	I	pcs / reel
G_226	8.00	2.80	2.25	4.00	1.10	0.30	4.00	∅ 1.50	1.75	3000
G_326	8.00	3.40	2.70	4.00	1.40	0.25	4.00	∅ 1.50	1.75	3000
G_534	12.00	5.30	3.60	8.00	1.40	0.30	4.00	∅ 1.50	1.75	1000
G_576	16.00	7.30	5.30	8.00	1.90	0.32	4.00	∅ 1.50	1.75	1000
G_43	24.00	11.80	10.00	16.00	5.00	0.30	4.00	∅ 1.50	1.75	500
G_63	24.00	11.80	10.00	16.00	5.00	0.30	4.00	∅ 1.50	1.75	500
G_JF538	12.00	5.30	3.60	8.00	1.40	0.30	4.00	∅ 1.50	1.75	1000
G_JF578	16.00	7.30	5.30	8.00	1.90	0.32	4.00	∅ 1.50	1.75	1000
(V)M21	8.00	2.30	1.90	4.00	0.90	0.25	4.00	∅ 1.50	1.75	3000
(V)ME21	8.00	2.30	1.50	4.00	1.35	0.25	4.00	∅ 1.50	1.75	3000
(V)M22	8.00	2.80	2.25	4.00	1.10	0.30	4.00	∅ 1.50	1.75	3000
(V)M_32	8.00	3.71	2.80	4.00	1.75	0.25	4.00	∅ 1.50	1.75	3000
(V)MQ_326	12.00	3.60	2.90	4.00	1.70	0.30	4.00	∅ 1.50	1.75	3000
(V)M_53	12.00	5.30	3.60	8.00	1.40	0.30	4.00	∅ 1.50	1.75	1000
(V)M_57(2)	16.00	7.40	5.50	8.00	2.80	0.35	4.00	∅ 1.50	1.75	500
(V)M_43 (63)	24.00	11.80	10.00	16.00	5.00	0.30	4.00	∅ 1.50	1.75	500

Reel Dimensions (unit : mm) ±2mm

	J	K	L	P	Q	R	pcs / reel
G_226	180.00	8.40	11.40	13.00	2.50	20.20	3000
G_326	180.00	9.00	12.00	13.00	2.50	20.20	3000
G_534	180.00	13.00	16.00	13.00	2.50	20.20	1000
G_576	180.00	17.20	19.30	13.00	2.50	20.20	1000
G_43	330.00	24.50	29.10	13.00	2.50	20.20	500
G_63	330.00	24.50	29.10	13.00	2.50	20.20	500
G_JF538	180.00	13.00	16.00	13.00	2.50	20.20	1000
G_JF578	180.00	17.20	19.30	13.00	2.50	20.20	1000
(V)M21	180.00	8.40	11.40	13.00	2.50	20.20	3000
(V)ME21	180.00	9.00	12.00	13.00	2.50	20.20	3000
(V)M22	180.00	8.40	11.40	13.00	2.50	20.20	3000
(V)M_32	180.00	9.00	11.40	13.00	2.50	20.20	3000
(V)MQ_326	180.00	13.00	16.00	13.00	2.50	20.20	3000
(V)M_53	180.00	13.00	16.00	13.00	2.50	20.20	1000
(V)M_57(2)	180.00	17.20	19.30	13.00	2.50	20.20	500
(V)M_43 (63)	330.00	24.50	29.10	13.00	2.50	20.20	500

Mercury www.mercury-crystal.com ■Taiwan : Tel: (+886)-2-2406-2779 / sales-tw@mercury-crystal.com

■USA : Tel: (+1)-909-466-0427 / sales-us@mercury-crystal.com ■China : Tel: (+86)-512-5763-8100 / sales-cn@mercury-crystal.com