

SAW TECHNO

sawtechno.ru

mail@sawtechno.ru

121351, Москва г., а/я 35

(499) 322-06-38

Общество с ограниченной ответственностью

«Научно-производственное предприятие «Техно-ПАРК»

(ООО «НПП «Техно-ПАРК»)

Юридический и фактический адрес: 121351, г. Москва,

ул. Ивана Франко, д. 48

Технические характеристики генератора

Производитель: Mercury Electronic Ind Co., Ltd.

Поставщик: ООО «НПП «Техно-ПАРК»

Научно-производственное предприятие ООО «НПП «Техно-ПАРК» разрабатывает и поставляет полосно-пропускающие радиочастотные фильтры на поверхностных акустических волнах (ПАВ) и устройства на их основе.

E-mail: mail@sawtechno.ru **Web:** www.sawtechno.ru

Ultra Low Jitter Differential Oscillator

Differential

HPJK

HDJK

HCJK

LVPECL Differential

LVDS Differential

HCSL Differential

SMD

1.8 V

2.5 V

3.3 V

Min.

100 MHz

Max.

250 MHz

Features

- Femto second integrated phase jitter (50 fs typical , 12 KHz to 20 MHz)
- Superior phase noise (-157 dBc/Hz at 100 KHz and -164 dBc/Hz at 10 MHz offset)
- Small size for 2.5 x 2.0 mm package

Jitter 50 fsec (typical)

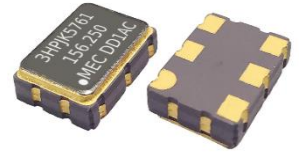

General specifications , at Ta=+25°C

Model	HPJK	HDJK	HCJK
Output Logic	LVPECL	LVDS	HCSL
Available Frequency Range	100 MHz ~ 250 MHz	100 MHz ~ 250 MHz	100 MHz ~ 175 MHz
Supply Voltage (V _{DD})	--	+ 1.8 V ± 5%	+ 1.8 V ± 5%
	+ 2.5 V ± 5%	+ 2.5 V ± 10%	+ 2.5 V ± 10%
	+ 3.3 V ± 10%	+ 3.3 V ± 10%	+ 3.3 V ± 10%
Output Load	50 Ω into V _{DD} - 2.0V or Thevenin equivalent	100 Ω between output and complimentary output	50 Ω to ground on each output
Rise Time / Fall Time (20%↔80% of waveform)	0.15 nsec (typ.)	0.15 nsec (typ.)	0.2 nsec (typ.)
	0.4 nsec (max.)	0.3 nsec (max.)	0.6 nsec (max.)
Current Consumption	52 mA (typ.) , 65 mA (max.)	22 mA (typ.) , 30 mA (max.)	32 mA (typ.) , 40 mA (max.)
Output Logic " High " , " 1 "	V _{DD} - 1.085 (min.) , V _{DD} - 0.86 (max.)	1.4 V (typ.) , 1.6 V (max.)	0.55 V (min.) , 1.0 V (max.)
Output Logic " Low " , " 0 "	V _{DD} - 1.81 (min.) , V _{DD} - 1.62 (max.)	0.9 V (min.) , 1.1 V (typ.)	- 0.15 V (min.) , 0.15 V (max.)
Output Swing (single-end)	400 mV (min.)	200 mV (min.)	450 mV (min.)

Frequency Stability Codes	Frequency Stability over Operating Temperature Range	± 25 ppm	± 50 ppm	± 100 ppm	If non-standard , please enter the desired stability after the "C " or " I " represents . For example : " C20 " ± 20 ppm over -10°C to +70°C ; " I30 " ± 30 ppm over -40°C to +85°C
	Commercial (-10°C to +70°C)	A	B	C	
	Industrial (-40°C to +85°C)	D	E	F	

Start-up Time	1.0 msec. (typ.) , 5.0 msec (max.)						
Duty Cycle	50% ± 5%						
Storage Temperature	- 55°C to + 150°C						
Aging at Ta = +25°C	± 3 ppm (max.) first year ; ± 2 ppm (max.) per year thereafter						
RMS Jitter (12 KHz to 20 MHz)	50 fsec (typ.) , 300 fsec (max.) [For 125 MHz , LVDS , 3.3V]						
Phase Noise [dBc / Hz (typ.)]	Offset	100 Hz	1 KHz	10 KHz	100 KHz	1 MHz	10 MHz
	125.0 MHz	-114	-135	-147	-157	-163	-164
	156.250 MHz	-108	-132	-141	-152	-160	-161
Output Enable / Disable Function	Enable	70% (min.) of V _{DD} to enable output. Enable time : 10 msec (max.)					
	Disable	30% (max.) of V _{DD} to disable output. Disable current : 30 uA (max.) [OE=GND] , Disable time : 0.2 usec (max.)					

Crystal Oscillators

HP_ [PECL Differential]

HD_ [LVDS Differential]

HC_ [HCSL Differential]

Part Number Format and Example

	[1]	[2]	[3]	-	[4]	-	[5]	
	Supply Voltage	Holder Type	1 or 2		Frequency Stability		Center Frequency	
Example	(1)	25	HCK536	1	-	C15	-	125.000
	(2)	18	HDK576	2	-	D	-	156.250
	(3)	3	HPK226	1	-	B	-	212.500
	(4)	25	HCJK536	1	-	A	-	125.000
	(5)	18	HDEK576	1	-	I30	-	156.250

- Ex (1) : 25HCK5361 - C15 - 125.000 [+2.5V, HCK type, HCSL output, 5.0 x 3.2 mm size, OE on pad 1, ±15 ppm from -10°C to 70°C, 125.000MHz]
 Ex (2) : 18HDK5762 - D - 156.250 [+1.8V, HDK type, LVDS output, 7.0 x 5.0 mm size, OE on pad 2, ±25 ppm from -40°C to 85°C, 156.250MHz]
 Ex (3) : 3HPK2261 - B - 212.500 [+3.3V, HPK type, LVPECL output, 2.5 x 2.0 mm size, OE on pad 1, ±50 ppm from -10°C to 70°C, 212.500MHz]
 Ex (4) : 25HCJK5361 - A - 125.000 [+2.5V, HCJK type, HCSL output, 5.0 x 3.2 mm size, OE on pad 1, ±25 ppm from -10°C to 70°C, 125.000MHz]
 Ex (5) : 18HDEK5761 - I30 - 156.250 [+1.8V, HDEK type, LVDS output, 7.0 x 5.0 mm size, OE on pad 1, ±30 ppm from -40°C to 85°C, 156.250MHz]

[1]	Supply voltage, " 18 " for +1.8V ; " 25 " for +2.5V ; " 3 " for +3.3V
[2]	Holder Type
[3]	" 1 " : OE function on pad # 1 , " 2 " : OE function on pad # 2
[4]	-10°C ~ 70 °C " A " ± 25ppm ; " B " ± 50ppm ; " C " ± 100ppm ; If non-standard please enter the desired stability after " C " , for example " C15 " : represents ±15ppm over -10 to +70°C
	-40°C ~ 85 °C " D " ± 25ppm ; " E " ± 50ppm ; " F " ± 100ppm ; If non-standard please enter the desired stability after " I " , for example " I30 " : represents ± 30ppm over -40 to +85°C
[5]	Frequency in MHz

Outline Dimensions (Unit : mm) , Suggested pad Layout for SMDs , Test Circuits

[H_K226]	[H_K326]	
[H_K536]	[H_K576]	
LVPECL Test Circuit	LVDS Test Circuit	HCSL Test Circuit
<p>$V_{DD} = 3.3V; R_1 = R_3 = 127 \Omega; R_2 = R_4 = 82.5 \Omega$ $V_{DD} = 2.5V; R_1 = R_3 = 250 \Omega; R_2 = R_4 = 62.5 \Omega$</p>		<p>$R_s = 0 \text{ to } 33\Omega \text{ to minimize ringing in application.}$</p>

Mercury www.mercury-crystal.com ■Taiwan : Tel: (+886)-2-2406-2779 / sales-tw@mercury-crystal.com

■USA : Tel: (+1)-909-466-0427 / sales-us@mercury-crystal.com ■China : Tel: (+86)-512-5763-8100 / sales-cn@mercury-crystal.com

Emboss Taping and Reel Specifications

[Crystal Oscillator Units]

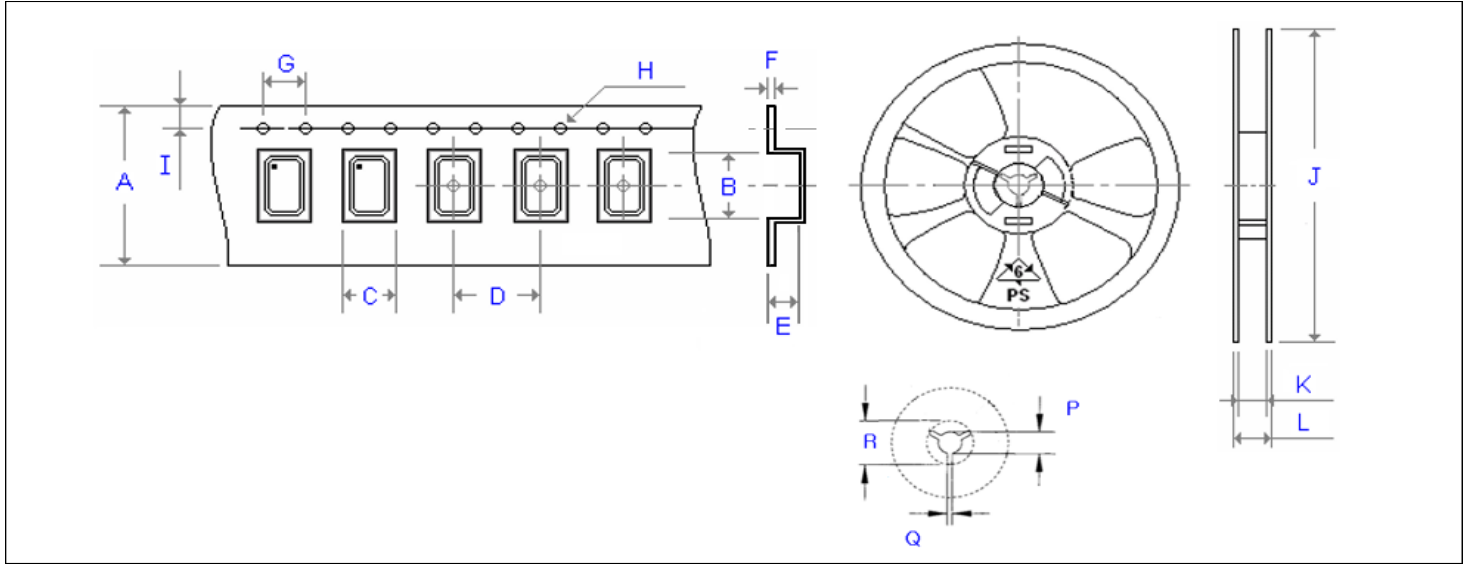

Carrier Type Dimensions (unit : mm) ±0.3mm

	A	B	C	D	E	F	G	H	I	pcs / reel
H21	8.00	2.30	1.90	4.00	0.90	0.25	4.00	∅ 1.50	1.75	3000
H_22	8.00	2.80	2.25	4.00	1.10	0.30	4.00	∅ 1.50	1.75	3000
H_32	8.00	3.40	2.70	4.00	1.40	0.25	4.00	∅ 1.50	1.75	3000
H_53	12.00	5.30	3.60	8.00	1.40	0.30	4.00	∅ 1.50	1.75	1000
H_57	16.00	7.30	5.30	8.00	1.90	0.32	4.00	∅ 1.50	1.75	1000
SWO	16.00	7.20	5.40	8.00	1.80	0.32	4.00	∅ 1.50	1.75	1000
H_226	8.00	2.80	2.25	4.00	1.10	0.30	4.00	∅ 1.50	1.75	3000
H_326	8.00	3.40	2.70	4.00	1.40	0.25	4.00	∅ 1.50	1.75	3000
H_536	12.00	5.30	3.60	8.00	1.40	0.30	4.00	∅ 1.50	1.75	1000
H_576	16.00	7.30	5.30	8.00	1.90	0.32	4.00	∅ 1.50	1.75	1000
H_JF328	8.00	3.40	2.70	4.00	1.40	0.25	4.00	∅ 1.50	1.75	3000
H_JF538	12.00	5.30	3.60	8.00	1.40	0.30	4.00	∅ 1.50	1.75	1000
H_JF578	16.00	7.30	5.30	8.00	1.90	0.32	4.00	∅ 1.50	1.75	1000
H_43	24.00	11.80	10.00	16.00	5.00	0.30	4.00	∅ 1.50	1.75	500

Reel Dimensions (unit : mm) ±2mm

	J	K	L	P	Q	R	pcs / reel
H21	180.00	9.00	12.000	13.00	2.50	20.20	3000
H_22	180.00	8.40	11.400	13.00	2.50	20.20	3000
H_32	180.00	9.00	12.000	13.00	2.50	20.20	3000
H_53	180.00	13.00	16.000	13.00	2.50	20.20	1000
H_57	180.00	17.20	19.300	13.00	2.50	20.20	1000
SWO	180.00	17.20	19.300	13.00	2.50	20.20	1000
H_226	180.00	8.40	11.400	13.00	2.50	20.20	3000
H_326	180.00	9.00	12.000	13.00	2.50	20.20	3000
H_536	180.00	13.00	16.000	13.00	2.50	20.20	1000
H_576	180.00	17.20	19.300	13.00	2.50	20.20	1000
H_JF328	180.00	8.00	12.000	13.00	2.50	20.20	3000
H_JF538	180.00	13.00	16.000	13.00	2.50	20.20	1000
H_JF578	180.00	17.20	19.300	13.00	2.50	20.20	1000
H_43	330.00	24.50	29.100	13.00	2.50	20.20	500

Mercury www.mercury-crystal.com ■Taiwan : Tel: (+886)-2-2406-2779 / sales-tw@mercury-crystal.com

■USA : Tel: (+1)-909-466-0427 / sales-us@mercury-crystal.com ■China : Tel: (+86)-512-5763-8100 / sales-cn@mercury-crystal.com