

Технические характеристики генератора JTS53HC

Производитель: Jauch

Поставщик: ООО «НПП «Техно-ПАРК»

Научно-производственное предприятие ООО «НПП «Техно-ПАРК» разрабатывает и поставляет полосно-пропускающие радиочастотные фильтры на поверхностных акустических волнах (ПАВ) и устройства на их основе.



actual size

Oscillator JTS53HC(V) · (VC)TCXO

- temp. compensated crystal oscillator, 5.0 x 3.2 mm
- low jitter Stratum 3 compliant TCXO / VCTCXO
- temperature range -40°C ~ +105°C available
- frequency stability of ± 50 ppb available
- ask for customized options



RoHS compliant



Pb free



REACH compliant



Conflict mineral free

GENERAL DATA

TYPE		JTS53HC / JTS53HCV (HCMOS output)
frequency range		9.60 ~ 50.0 MHz (see table 4 on next page)
frequency tolerance / stability	at +25 °C (*1)	± 1.0 ppm max.
	after 2x reflow (*2)	± 0.5 ppm max.
	temperature (*3)	see table 1
	supply voltage (*4)	± 0.1 ppm max. (at V _{DC} ± 5%)
	load change (*5)	± 0.1 ppm max. (at nom load ± 5%)
	aging first year (*6)	± 1.0 ppm max. (at +25 °C)
	aging per day (*7)	± 20.0 ppb max.
	short term (ADEV)	0.2 ppb max. / 0.1 ppb typ. with τ = 1 sec
holdover stability (*8)		± 0.37 ppm max.
free run frequency stability (*9)		± 4.6 ppm max.
current consumption max.		10.0 mA max.
supply voltage V _{DC}		3.3V (all ± 5%)
temperature	operating	see table 1
	operable	-40 °C ~ +105 °C
	storage	-55 °C ~ +105 °C
output	rise/fall time max.	8ns (10% <-> 90% of VDC)
	load max.	15 pF
	low level max.	0.4V
	high level min.	V _{DC} - 0.4V
	start-up time max.	

TABLE 1: FREQUENCY STABILITY CODE

frequency stability temperature code	F	H	G	J
	± 0.28 ppm	± 0.20 ppm	± 0.10 ppm	± 0.05 ppm
-30 °C ~ +75 °C	G	○	○	○
-40 °C ~ +85 °C	K	○	○	○
-40 °C ~ +105 °C	P	○	○	▷

○ available ▷ ask if available

TABLE 2: VC DEPENDENT FREQUENCY TUNING RANGE CODING METHOD

V _C frequency tuning range of JTS53HCV	code	minimal	maximal
table shows examples, ask for more options	05X0	± 5.0 ppm	undefined
	08X0	± 8.0 ppm	undefined
	0510	± 5.0 ppm	± 10.0 ppm
	1015	± 10.0 ppm	± 15.0 ppm

TABLE 3: VC CODING METHOD (EXAMPLES)

V _C center voltage and V _C range	code	center of V _C	range of V _C	
	1616	1.65 V	± 1.65 V	1.65 V ± 1.65 V at V _{DC} = 3.3 V
	1610	1.65 V	± 1.00 V	1.65 V ± 1.00 V at V _{DC} = 3.3 V
	1515	1.50 V	± 1.50 V	1.50 V ± 1.50 V at V _{DC} = 3.3 V
	1510	1.50 V	± 1.00 V	1.50 V ± 1.00 V at V _{DC} = 3.3 V
V _C properties	input impedance of V _C min.		100 kOhm	
	V _C frequency tuning linearity max.		10 %	

For (*1) ~ (*9) please refer to definitions shown on the 2nd page of this datasheet

DIMENSIONS

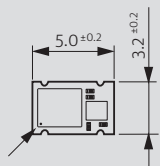

top view example

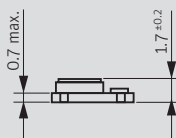

side view example

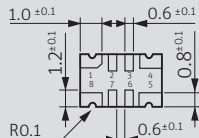

bottom view

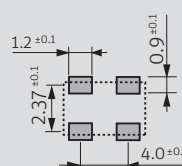

pad layout

TCXO JTS53HC

- 1: NC
- 2, 3: NC
- 4: GND
- 5: output
- 6, 7: NC
- 8: V_{CC}

VCTCXO JTS53HCV

- 1: VC
- 2, 3: NC
- 4: GND
- 5: output
- 6, 7: NC
- 8: V_{CC}

pin connection

in mm

ORDER INFORMATION

0	frequency	type	frequency stability code	operating temp. code	supply voltage	control voltage (for JTS53HCV)	tuning range (for JTS53HCV)
Oscillator	9.60 ~ 50 MHz	JTS53HC = TCXO JTS53HCV = VCTCXO	F = ± 0.28 ppm H = ± 0.20 ppm G = ± 0.10 ppm J = ± 0.05 ppm	G = -30°C ~ 75°C K = -40°C ~ 85°C P = -40°C ~ 105°C	3.3 = 3.3 V	see table 3	see table 2

Example: 0 10.0-JTS53HCV-F-K-3.3-1510-1015-LF (Suffix LF = RoHS compliant / Pb free)

Oscillator JTS53HC(V) · Stratum 3 TCXO & VCTCXO

PHASE NOISE INFORMATION		
phase noise at f0 19.2 MHz, V _{DC} = 3.3 V @ +25 °C	at 10 Hz	-93 dBc/Hz typ.
	at 100 Hz	-120 dBc/Hz typ.
	at 1 KHz	-145 dBc/Hz typ.
	at 10 KHz	-157 dBc/Hz typ.
	at 100 KHz	-159 dBc/Hz typ.

PACKAGING NOTE
- non-multiple packing units are only supplied taped / bulk
- moisture sensitivity: MSL 2

DEVELOPED FREQUENCIES					
all frequencies in MHz:	10.0	12.80	13.0	16.320	16.3840
	18.4320	19.20	19.440	20.0	25.0
	30.720	32.7680	38.880	40.0	50.0

NOTE
- for best supply noise rejection, connect a capacitor of 100nF and a second capacitor of 10µF closely to the supply voltage pins
- a separate voltage supply rail ensures best phase noise
- keep digital or high frequency signals as far away from V _C pin as possible

DEFINITIONS
*1: Measured frequency observed with T _A =+25°C and C _L =15pF, at nominal V _{DC} and nominal center V _C (if applicable) within 30 days after ex-factory. The measured frequency is referenced to the specified nominal frequency.
*2: At specified reflow soldering profile, tested with T _A =+25 °C and C _L =15pF, at nominal V _{DC} and nominal center V _C (if applicable). At least 4 hours of static placement at room temperature is necessary after completion of 2 times reflow.
*3: T _A varied in the specified operating temperature range, frequency variation is normalized to the middle point of whole frequency excursion, at nominal V _{DC} and nominal center V _C (if applicable), and at nominal output load, temperature variable speed less than 2°C per minute.
*4: Frequency variation if V _{DC} is varied by ± 5% of nominal V _{DC} , frequency variation is normalized to frequency observed at nominal V _{DC} , nominal center V _C (if applicable), T _A =+25 °C and nominal load.
*5: Frequency variation if the load is varied by ± 5% of nominal load, frequency variation is normalized to frequency observed at nominal V _{DC} , nominal center V _C (if applicable), T _A =+25 °C and nominal load.
*6: The maximum 1st-year frequency deviation from the ex-factory status. T _A =+25 °C, at nominal V _{DC} , nominal center V _C (if applicable), T _A =+25 °C and nominal load. Normally, the largest frequency deviation occurs within the 1st year.
*7: The maximum frequency deviation within 24 hours in a steady state. The initial status acquired at T _A =+25 °C, at nominal V _{DC} , nominal center V _C (if applicable), nominal load and after 1h of continuous operation.
*8: The maximum frequency deviation within 24 hours including temperature variation. The initial status acquired at T _A =+25°C, at nominal V _{DC} , nominal center V _C (if applicable), nominal load and after 1h of continuous operation.
*9: The maximum frequency deviation including stability vs. temperature, tolerance ex. factory, aging over 20 years, supply and load variation.

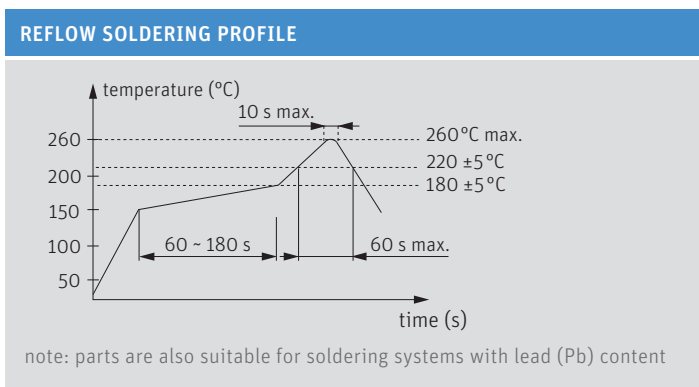
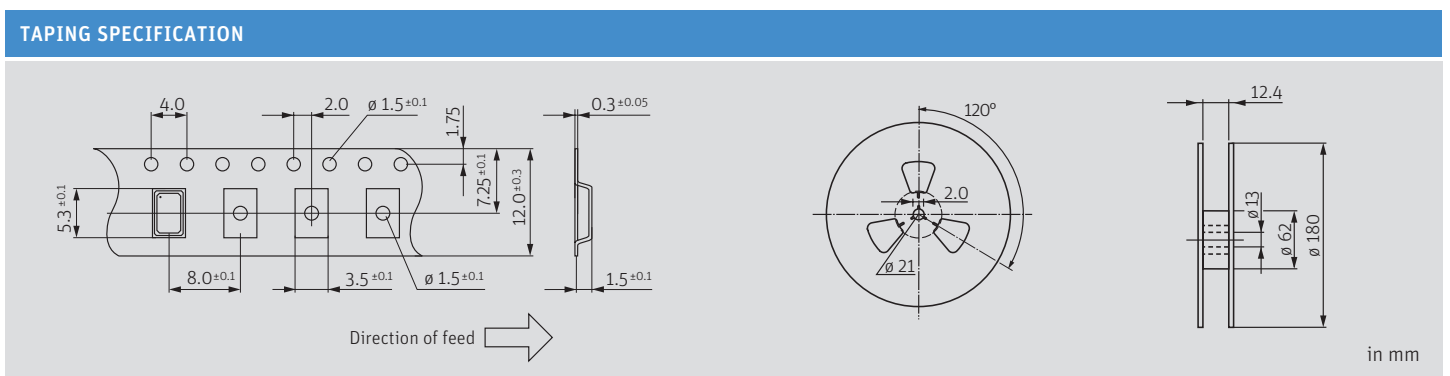

MARKING
frequency / internal code (optional)
dot / D / date code (YYW) or dot / date code (YYWW)
date code: one digit for year and two digits for week
2: 2022 3: 2023 4: 2024 5: 2025 6: 2026 7: 2027
note: the date code on the metal lid does not show the datecode of the final assembly of the (VC)TCXO. The final assembly date is later than the datecode shown on the metal lid